



# CROWN ELECTRONICS



## Crown P/N: CRN-1526

Crown Electronics  
Box 49  
Farmersville, TX 75442

972-771-4711  
800-225-3429 (toll free)

For More Information:

[Sales@crownelectronics.com](mailto:Sales@crownelectronics.com)

**Description:** N (Female) Crimp RG-214

**Body:** Nickel / Brass

**Insulation:** Teflon

**Contact:** Gold / Beryllium Copper

\*\*\* ROHS COMPLIANT \*\*\*

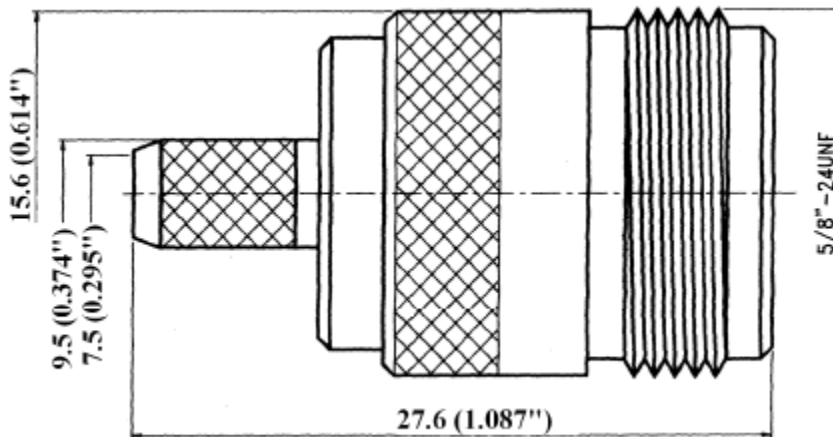

### Stripping Information:

All Measurements are in

(Inches)  
Millimeters

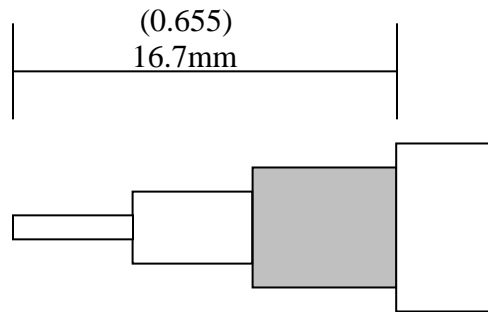

(0.200)	(0.130)	(0.325)
5.1mm	3.3mm	8.3mm